

HERMA H400

Overview

Label Applicator

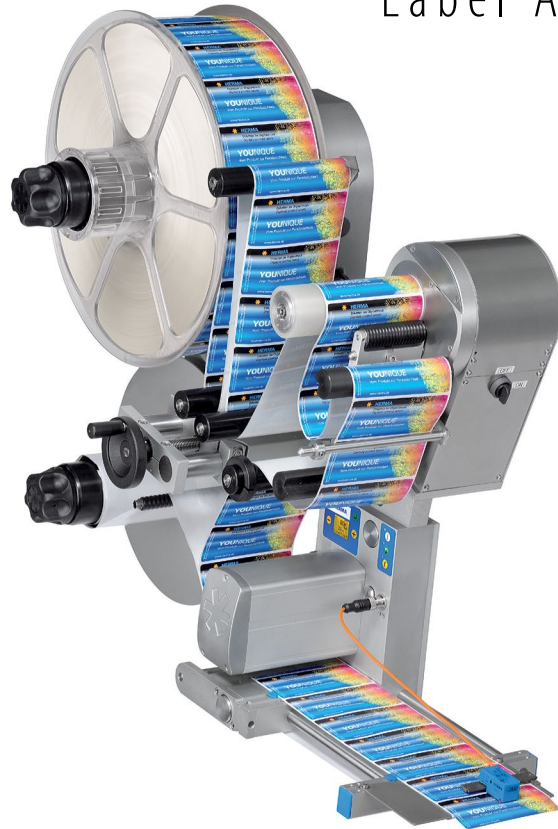

Special Features

- Controller and operating display is built in; no separate controls required
- Automatic synchronization of labeling and product handling speeds
- Special unwind unit provides consistent web tension
- Applies labels up to 6.3" wide standard, 12.6" wide optional
- IP66 rated for dust and water protection

HERMA H400 Series label applicators provide speed, precision and true modularity.

The HERMA H400 Series from Weber is one of the most versatile wipe-on pressure-sensitive label applicators due to its variety of unique, modular configurations.

The key is the system's basic servo drive unit, which remains the same throughout the H400 Series. This dependable motor powers the entire range of modules Weber offers. As a result, any H400 Series applicator easily can be reconfigured for higher-speeds or for an alternate method of application if future labeling demands change.

Because this system features so many modules and a built-in controller, the H400 Series can be integrated with practically any existing production line. Or Weber can build the unit into a custom product handling system specifically developed for an individual application.

The HERMA H400 Series comes with a list of features that allows you to have the ultimate in flexibility and control over your labeling operation including:

- Comprehensive selection of modules
- Right- or left-hand configurations
- Easily connects to PLCs
- Handles transparent labels without incident
- Simple to expand or reconfigure



Clearly-defined display panel facilitates adjustments to operational parameters; provides 30 preset functions

HERMA H400

General Specifications

Label Applicator

Standard Unwind

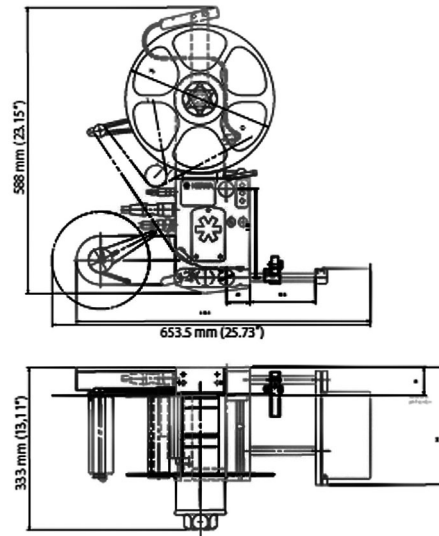

Weight: approx. 35 lbs.

Motorized Unwind/Rewind

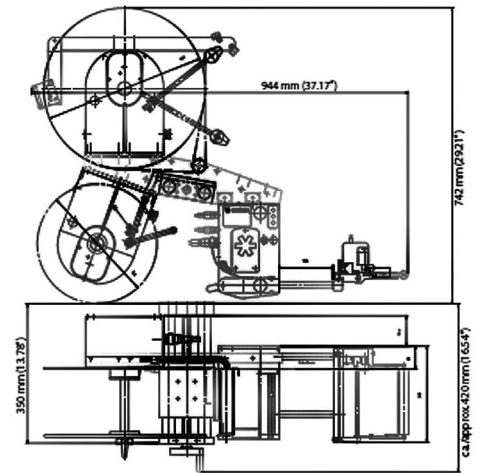

Weight: approx. 66 lbs.

Standard Modules

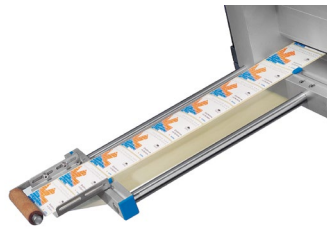

Rigid peel bar with application roller

For linear labeling; spring-loaded roller applies the label onto the product

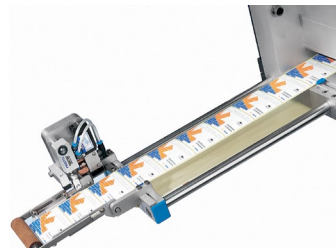

Pivot peel bar with application roller

For linear labeling of products with varying heights or uneven shapes



Special sensor

Especially suitable for transparent labels; fast and powerful

Custom application heads

For labeling that requires direct tamp, tamp-blow or air-blow application

Motor(s)

Servo-driven

Electrical

Universal 100-240VAC, 50-60Hz

Weight

Standard Unit: Approx 35 lbs.
(Up to 66 lbs. with unwind/rewind options)

Accuracy

±0.01" when product handling is controlled

Label Widths

Standard: Up to 6.3"
Optional: Up to 12.6"

Labeling Speeds

Standard: Up to 130 feet per minute
Optional: Up to 590 feet per minute

Protection Rating

IP66 rated for dust and water protection

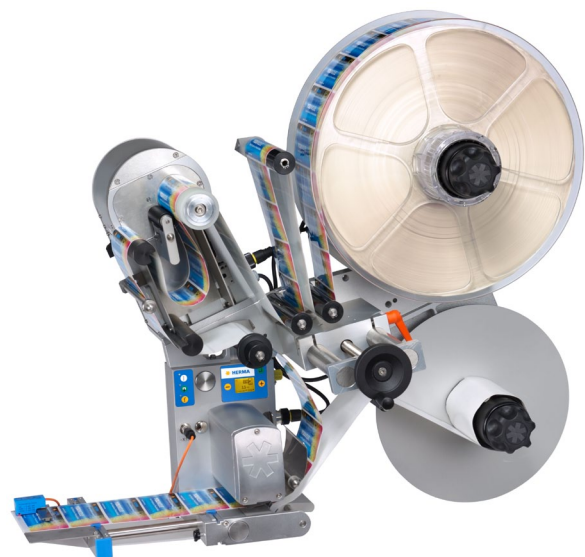

Motorized Unwind/Rewind