

Alpha Compact

Overview

Label Applicator



Special Features

- Applies labels up to 4.7" wide x 11.8" long
- Operates at up to 164 feet/minute
- Labels tops, bottoms or sides of packages
- Accurate labeling to within ± 0.03 "

Weber's Alpha Compact label applicator is a cost-effective solution to fast, reliable pressure-sensitive labeling. This system features a small footprint, yet employs a highly-accurate wipe-on method of application to affix p-s labels on the production line.

The Alpha Compact unit automatically unwinds the supply roll and peels the labels from their liner, then wipes them on to products, cartons and other packages as they travel past the system on a conveyor line. This system applies labels up to 4.7" wide and 11.8" long at speeds up to 164 feet per minute to a tolerance of ± 0.03 ".

The versatile unit can be oriented to apply labels to the sides, tops or bottoms of packages. To accommodate various production environments, the Alpha Compact can be specified for right- or left-hand applications.

Three Interfaces

Depending upon the complexities and demands of the particular labeling operation, the Alpha Compact is available with three separate interfaces:

- Panel HMI includes an external operator's panel that provides system control through a pair of potentiometers and four push-buttons.
- Display HMI replaces the operator's panel with an LCD display that provides full access to all adjustment parameters.
- USB utilizes a USB connection that permits the unit to be configured from a PC.

Each version of the Alpha Compact features rugged die-cast aluminum construction, single-key calibration, automatic recognition of missing labels, in-production speed adjustment, and more.

Alpha Compact

General Specifications

Label Applicator

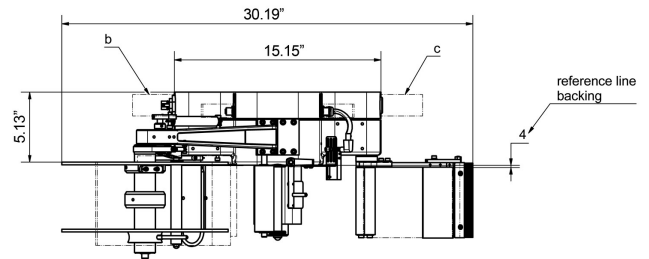
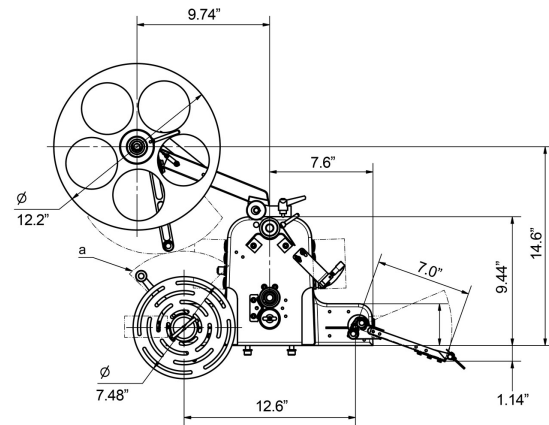
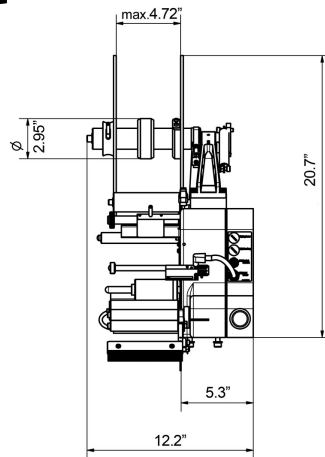

Dimensions

28.15" x 12.2" x 23.22"
(715mm x 310mm x 590mm)

Weight

48.5 lbs. (22kg)

Electrical

115/230 VAC, 47/63Hz

Product Sensing

Photoelectric

Label Roll Size

Up to 12" O.D. (300mm) wound on 3" (76mm) core

Label Styling

Die-cut, waste-removed with a minimum of 0.125" (3mm) separation between labels in running direction

Label Placement

Accurate to $\pm 0.03"$ (0.8mm) when labels are produced to specifications and product handling is controlled

Standard Label Sizes

Min width: 0.4" (10mm)
Max width: 4.7" (120mm)
Min length: 0.78" (20mm)
Max length: 11.8" (300mm)

Labeling Speed

Up to 164 fpm (50m) depending on label roll width and diameter

Options

- Adjustable stand
- Encoder
- Low-label sensor
- Three-color stack light
- USB connection
- I/O connection